

KENWOOD
HI/FI STEREO COMPONENTS

SERVICE MANUAL

KC-6060A

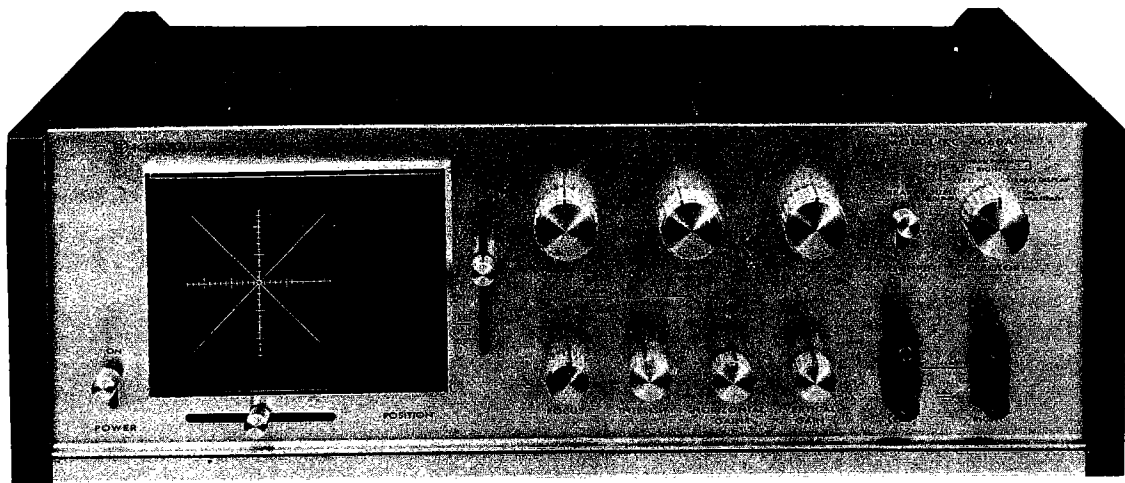

SOLID STATE AUDIO LAB-SCOPE

PARTS DESCRIPTION LIST

Symbol No.	Description	Part No.	Remarks
MAIN CHASSIS (Y15-0005-01) SECTION			
PC BOARD			
—	OSCILLATION UNIT (UM1302J)	X71-0002-00	
—	VERTICAL & HORIZONTAL DEFLECTION UNIT (UM1508J)	X73-0008-00	
—	POWER & HIGH-TENSION UNIT (UM1008J)	X68-0008-00	
CAPACITOR			
C101, 102	Polyester	0.47 μ F \pm 20%	CQ05M2G474M
C103, 104	Ceramic	10pF \pm 0.5pF	CC94SL2H100D
C105	Electrolytic	10 μ F 25WV	CE04W1E100
C108	Mylar	0.47 μ F \pm 10%	CQ93M1H474K
C109	Mylar	0.047 μ F \pm 10%	CQ93M1H473K
C110	Mylar	0.0039 μ F \pm 10%	CQ93M1H392K
C111	Mica	270pF \pm 10%	CM91B2H271KY
C112, 113	Electrolytic	47 μ F 315WV	CE02D2F470
C114	Oil Impregnated	0.1 μ F \pm 20%	CP02B3C104M
C115a, b	Oil Impregnated	0.2 μ F \pm 10%	C90-0039-05
C116	Oil Impregnated	0.01 μ F \pm 20%	C90-0036-05
C117	Oil Impregnated	0.1 μ F \pm 20%	CP02B2J104M
C118	Mylar	0.01 μ F \pm 10%	CQ93M1H103K
RESISTOR			
R101, 102	Insulated Carbon Film	220k Ω \pm 5% 1/2W	PD14BY2H224J
R103, 104	Insulated Carbon Film	27k Ω \pm 5% 1/4W	PD14BY2E273J
R105	Insulated Carbon Film	1M Ω \pm 5% 1/2W	PD14BY2H105J
R106	Insulated Carbon Film	150k Ω \pm 5% 1/4W	PD14BY2E154J
SWITCH			
S101a, b	AUDIO INPUT (Lever)		S36-2002-25
S102	SELECTOR (Rotary)		S10-4039-05
S103	SWEEP RANGE (Rotary)		S29-1004-05
S104	AC VOLTAGE SELECT (Slide)		S31-2004-05
POTENTIOMETER			
VR101	Vertical Gain	250k Ω (B)	R03-6001-05
VR102	Horizontal Gain	250k Ω (B)	R03-6001-05
VR103	1kHz OSC	10k Ω (B)	R03-3001-05
VR104	Sweep Variable	1M Ω (B)	R16-8001-05
VR105	Vertical Position	50k Ω (B)	R13-3002-15
VR106	Horizontal Position	50k Ω (B)	R13-3002-15
VR107	Intensity	250k Ω (B)	R03-6002-05
VR108	Focus	1M Ω (B)	R03-8001-05
VR109	Level Adj.	100k Ω (B)	R02-5003-05
VR110	Level Adj.	100k Ω (B)	R02-5003-05
VR111	Multipath Position Deflection	100k Ω (B)	R12-5014-05
etc.			
—	Case		A01-0070-03
—	Frame (1)		A13-0007-03
—	Frame (2)		A13-0008-03
—	Frame (3)		A13-0009-03
—	Frame (4)		A13-0010-03

PARTS DESCRIPTION LIST

Symbol No.	Description	Part No.	Remarks
—	Frame (5)	A13-0010-03	
—	Panel	A20-0002-22	
—	Panel Assembly	A20-0095-23	
—	Sub-Panel	A22-0011-22	
—	Rear-Panel	A23-0173-12	
—	Sole-Plate	A40-0006-03	
—	Scale	B20-0023-14	
P. L.	Pilot Lamp	B30-0029-15	
—	Certification	B42-0009-04	
—	Caution Sticker (For Cathode-ray tube)	B42-0026-04	
—	LA Standard Sticker	B42-0220-04	
—	Warranty Card	B46-0002-00	
—	Warranty Card (U)	B46-0037-00	
—	Instruction Manual (K)	B50-0465-10	
—	Instruction Manual (U)	B50-0466-10	
—	Schematic Diagram	B52-0074-00	
—	Caution Card (For Power) (U)	B58-0003-00	
—	Caution Card (For Case) (K)	B58-0043-00	
—	Caution Card (For Power) (U)	B58-0101-00	
—	Address (U)	B59-0018-00	
—	Switch Stopper	D32-0021-04	
—	14P Cathode-ray Tube Socket	E01-1401-05	
J	1P Pin Jack	E13-0104-05	
J	6P Pin Jack	E13-0601-05	
—	Pilot Lamp Socket	E15-0010-05	
—	Lug Terminal	E20-0509-05	
—	Terminal	E21-0201-03	
—	Lug	E22-0207-05	
—	AUDIO Cord	E30-0015-05	
—	Power Cord	E30-0046-05	
F	Fuse (1A)	F05-1023-05	
—	Shielding Plate	F10-0181-14	
—	Shielding Plate (For Rotary Switch)	F10-0190-04	
—	Shielding Plate (For Cathode-ray Tube)	F11-0119-02	
—	Dust Sheet	F15-0007-04	
—	Case Patch	F19-0033-03	
—	Case Patch	F19-0034-03	
—	Cushion	G13-0006-25	
—	Rubber Sheet	G16-0002-14	
—	Corrugated Cardboard Case	H01-0517-03	
—	Corrugated Cardboard Case (K)	H02-0118-03	
—	Legs	J02-0010-04	
—	Bezel (For Observation)	J10-0004-03	
—	Bezel Framework (For Observation)	J10-0005-04	
—	Fuse Holder	J13-0016-05	
—	Transformer Holder	J21-0007-04	
—	Cathode-ray Tube Holder	J21-0051-03	
—	Pilot Lamp Holder	J21-0052-13	
—	Amp Holder	J21-0192-04	
—	Cathode-ray Tube Holder	J21-0731-04	
—	Cathode-ray Tube Holder	J21-0732-04	

PARTS DESCRIPTION LIST

Symbol No.	Description	Part No.	Remarks
—	Collar (1)	J31-0004-04	
—	Collar (2)	J31-0005-04	
—	Boss	J32-0015-04	
—	Power Cord Bushing	J41-0006-00	
—	Rubber Bushing	J42-0009-04	
—	Snap Beaded Band	J61-0017-05	
—	Beaded Band	J61-0018-05	
—	Knob (16 ϕ)	K20-0013-14	
—	Knob (23 ϕ)	K20-0054-04	
—	Knob (For Lever)	K29-0015-14	
P. T.	Power Transformer	L03-0005-15	
—	GND Terminal	N08-0002-04	
<i>In North America, leave out the parts of "U", In other area, do out the parts of "K", but In Canada, not including the Switch S104.</i>			

EXTERNAL VIEW

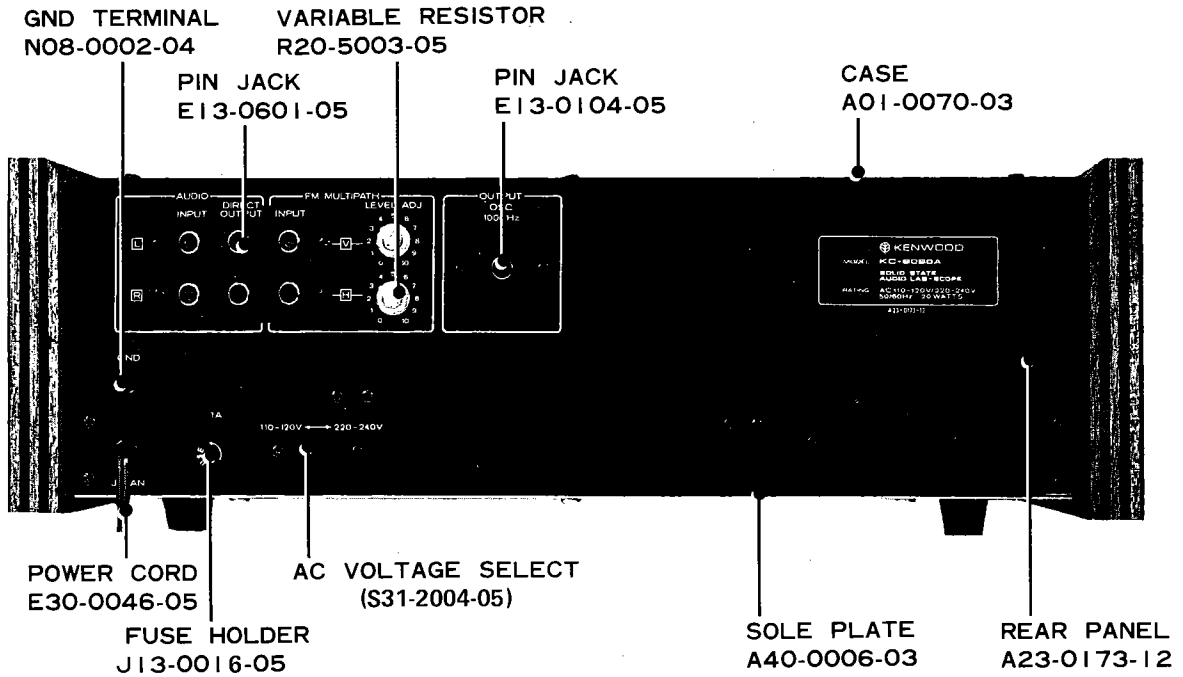
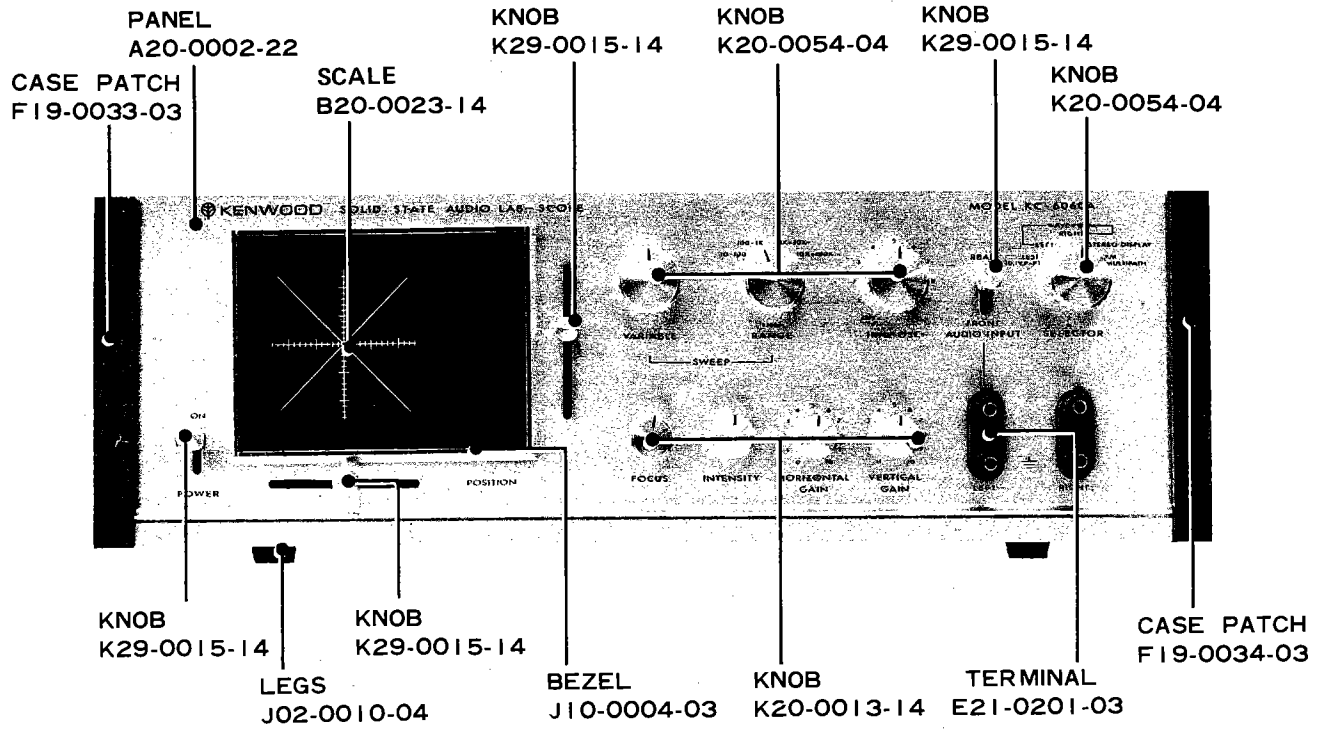

CHASSIS TOP & BOTTOM VIEW

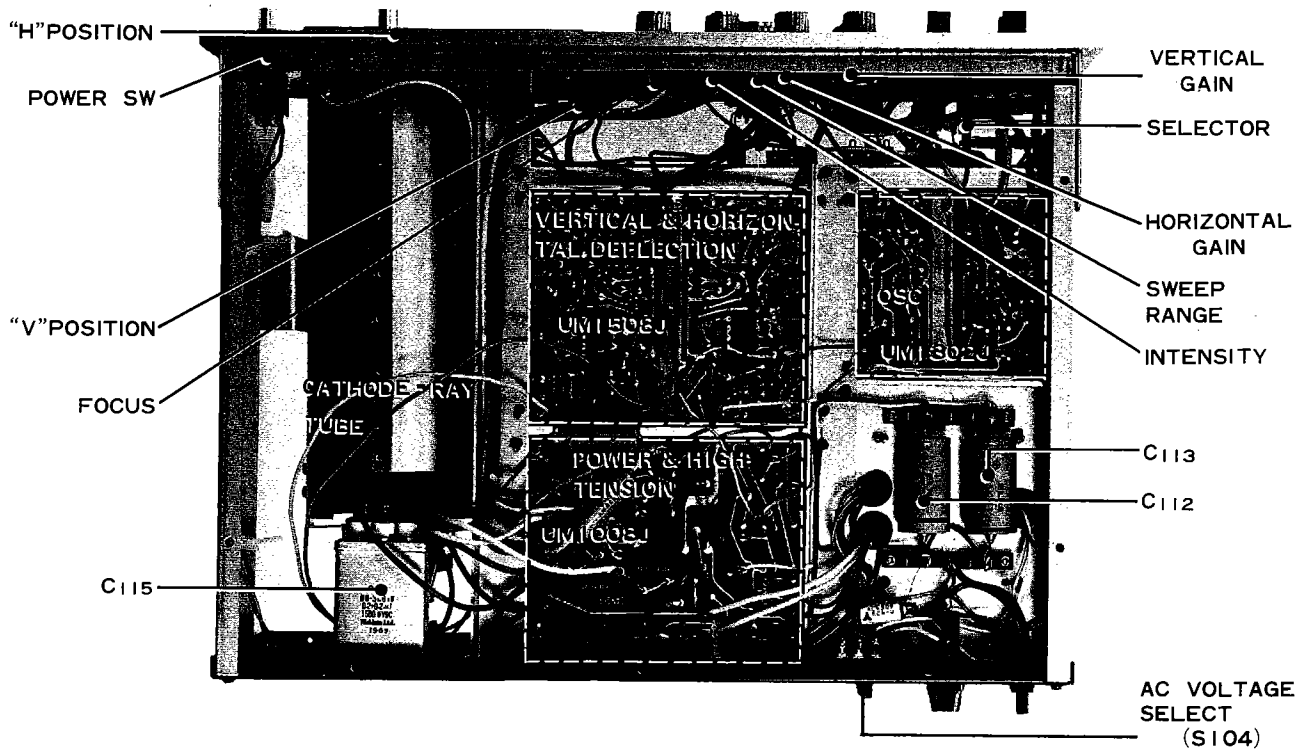
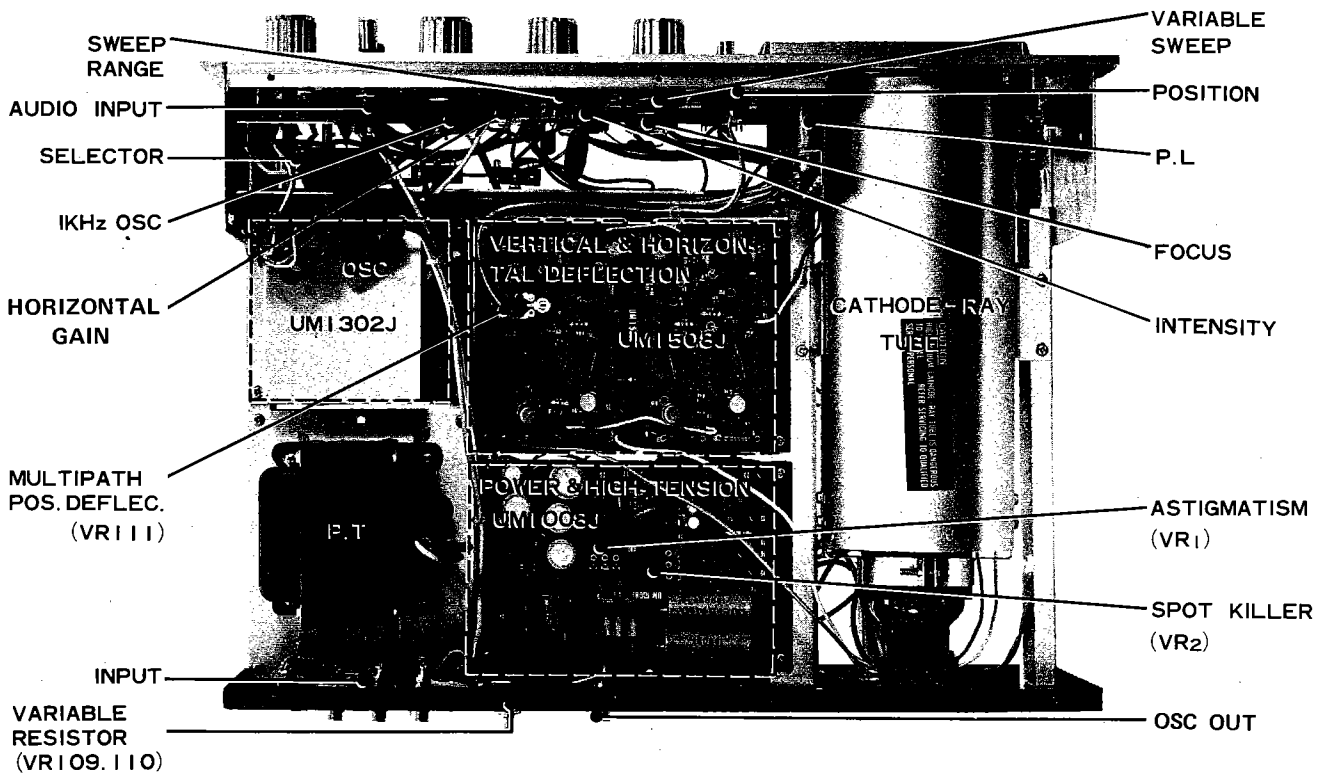

SCHEMATIC DIAGRAM

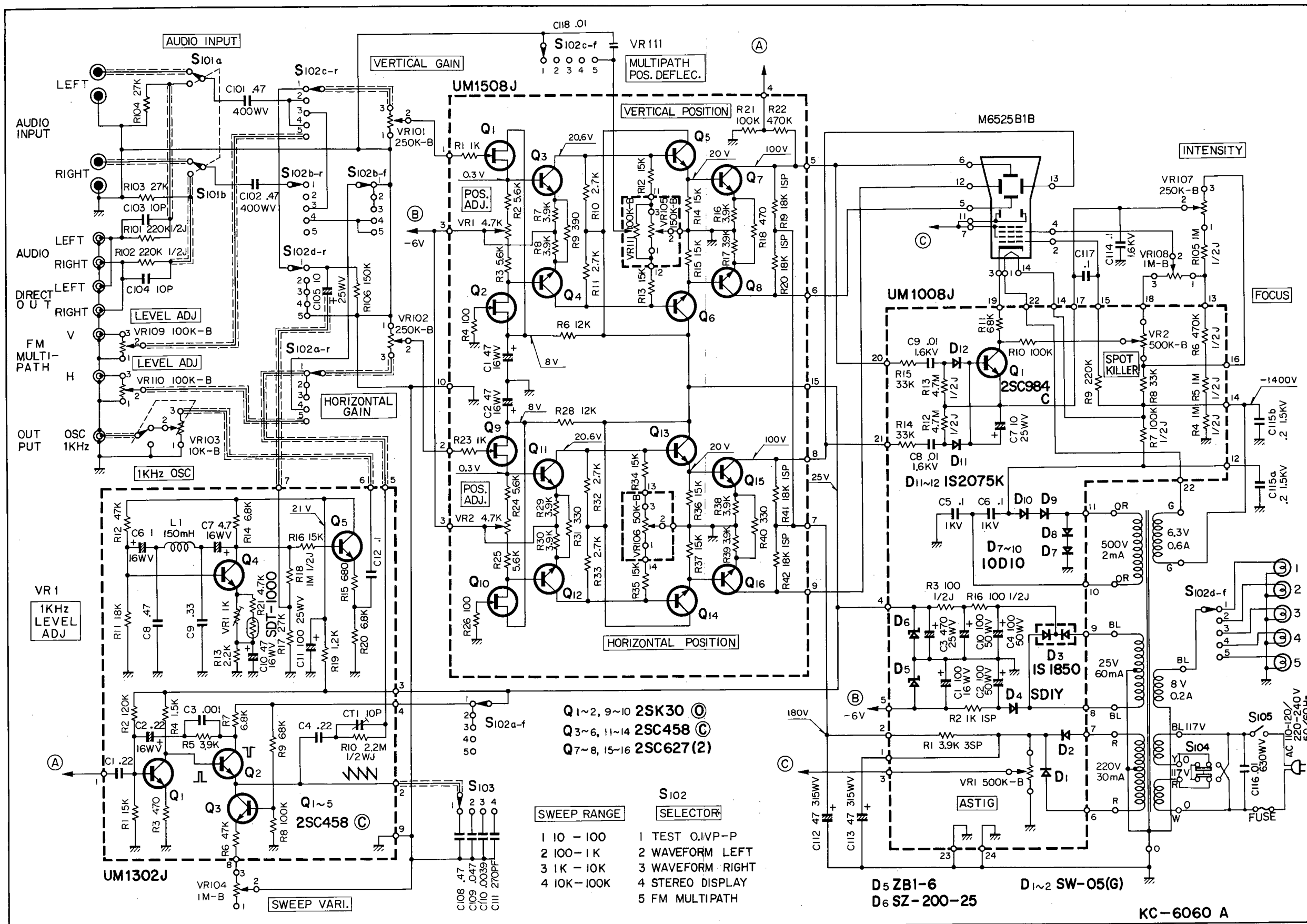

ALIGNMENT PROCEDURE

I. General

This manual contains the descriptions for alignment of the model KC-6060A Solid State Audio Lab-Scope.

II. Measuring Instruments and Tools Required

1. Measuring instruments

- 1) Sine wave oscillator
Frequency: 10 Hz to 500 kHz or more
Distortion factor: 1% or less
Output: Shall provide least level variation
- 2) Square wave oscillator
Frequency requirement: Shall be capable of delivering a frequency of 50 Hz
Output: Shall be such that its waveform suffers from least sag
- 3) Square wave voltage calibrator
Shall be a square wave oscillator which is capable of delivering the square wave voltage (P-P) with precision at 1 kHz. Not required specifically if the square wave oscillator given in item 2) meets the above requirement.
- 4) AC voltmeter
Frequency: 5 Hz to 500 kHz
Accuracy: 3% or less (10 Hz to 200 kHz)
- 5) Oscilloscope
This oscilloscope is intended to use as a monitor for the output level of the sine wave oscillator given in item 1) above. If the sine wave oscillator is highly stable, therefore, it is unnecessary to prepare this oscilloscope specifically.
- 6) Distortion factor meter

2. Tools

- 1) Regulating rod
- 2) Philips screwdriver

III. Adjustment of Bright Spot and Line

1. Purpose

The purpose of this adjustment is to position the bright spot at the center of the cathode-ray tube scope when controls POSITION "V" and "H" are set to the centers of their movable ranges.

The another purpose is to make the astigmatism adjustment of the bright spot and the horizontal adjustment of the cathode-ray tube scale to the bright line.

2. Position adjustment

- 1) Set the operating controls on the front panel as follows:
POSITION (V & H): Mechanical center
FOCUS: Center
INTENSITY: 3 o'clock position
SWEEP VARIABLE: Center
SWEEP RANGE: 100 – 1K
SELECTOR: TEST (0.1 Vp-p)
- 2) Vertical center adjustment
With control HORIZONTAL GAIN set at the center position and control VERTICAL GAIN set at the extreme counterclockwise position, adjust variable resistor VR1 on printed circuit board UM1508J until the bright line is centered on the cathode-ray tube scope with respect to its vertical position.
- 3) Horizontal center adjustment
With control HORIZONTAL GAIN set at the extreme counterclockwise position and control VERTICAL GAIN at the center position, adjust variable resistor VR2 on printed circuit board UM1508J until the bright line is centered on the cathode-ray tube scope with respect to its horizontal position.

3. FM multipath spot position adjustment

- 1) Set the SELECTOR to FM multipath.
Set other controls on the panel as described in item 2.
- 2) With the "VR111" on the printed circuit board UM1508J adjust the spot position so that it is set within 22 ± 2 mm below the center of the scale.

4. Astigmatism adjustment

- 1) Set controls HORIZONTAL GAIN and VERTICAL GAIN at their extreme counterclockwise position. Check to see that other controls are set as given in item 2, 1) above.
- 2) With variable resistor VR2 on printed circuit board UM1008J set at the extreme counterclockwise position, adjust variable resistor VR1 on the same printed circuit board until the bright spot becomes a round, small spot at the center of the cathode-ray tube scope.

5. Spot killer adjustment

With all operating controls set as described in item 4 above, turn variable resistor VR2 on printed circuit board

UM1008J until the bright spot on the cathode-ray tube scope goes out. Fix the variable resistor at that position.

6. Horizontal adjustment of cathode-ray tube scale to bright line

Set control VERTICAL GAIN at the extreme counterclockwise position and control HORIZONTAL GAIN at the center position. Adjust the screws of the cathode-ray tube mounting bracket as illustrated below until the horizontal axis of the cathode-ray tube scale coincides with the bright line.

■ *The set has two type construction.*

Adjustment can be obtained by following either of the steps given below depending on the type.

Loosen this screw. Rotate the CRT until the horizontal axis of the CRT scale coincide with the bright line. Tighten the screw to fix the tube in that position.

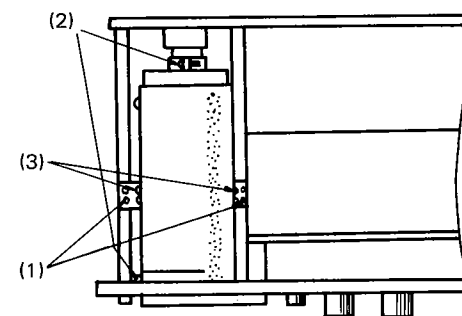
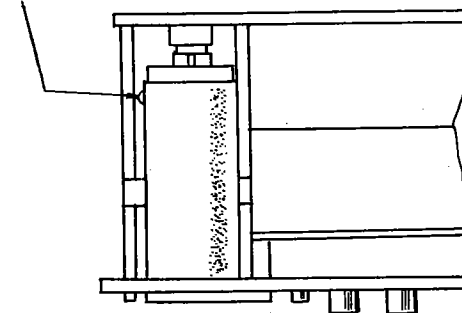

- (1) If CRT is not centered on the scale, vertical and horizontal, left and right adjustments can be obtained with these screws turned loose.
- (2) Loosen these screws and bring the bright line into alignment with the horizontal level and then tighten the screws.
- (3) Fine adjustment can be obtained with this screw.

7. Check of performance INTENSITY control

With the VERTICAL GAIN control set at the center

position, check to see that the bright line increases its intensity as the INTENSITY control is turned clockwise. Also, check under the above condition to see that the bright line decreases its intensity uniformly until it goes out as the INTENSITY control is turned counterclockwise.

IV. Check of Deflection Sensitivity

1. Purpose

The purpose of this check is to make sure that the cathode-ray tube scope provides a vertical and a horizontal deflection sensitivities of 25 mV/cm or more.

2. Check of Vertical Deflection Sensitivity

- 1) Set the operating controls on the front panel as follows:
POSITION (V & H): Mechanical center
INTENSITY: 3 o'clock position
FOCUS: Any position for which bright spot is focussed properly

SWEEP RANGE: 100 – 1K
HORIZONTAL GAIN: Center
VERTICAL GAIN: Extreme clockwise
SELECTOR: WAVEFORM LEFT
AUDIO INPUT: FRONT
- 2) Set up the square wave voltage calibrator for an output of 0.1 Vp-p at 1 kHz. Connect the output of the calibrator to the LEFT input terminal on the front panel. Check that the input signal is vertically deflected more than 40 mm as measured on the cathode-ray tube scope. In this case, adjust the SWEEP VARIABLE control so as to prevent the waveform running in the horizontal direction over the scope.
- 3) Set the SELECTOR switch at the WAVE FORM RIGHT position. With the output of the calibrator connected to the RIGHT input terminal, check to see that the input signal is vertically deflected more than 40 mm as in item 2) above.
- 4) Connect the output of the calibrator to the LEFT input terminal with the SELECTOR switch set at the STEREO DISPLAY position and check to see that the input signal is deflected just in the same manner as mentioned above.
- 5) With the operating controls set as follows, check to see that the terminals on the rear panel provide a deflection sensitivity of more than 40 mm respectively

ALIGNMENT PROCEDURE

against their inputs.

AUDIO INPUT: REAR

SELECTOR's position	Input terminal	Calibrator's output
WAVE FORM LEFT	AUDIO INPUT "L"	1 Vp-p
WAVE FORM RIGHT	AUDIO INPUT "R"	1 Vp-p
STEREO DISPLAY	AUDIO INPUT "L"	1 Vp-p
FM MULTIPATH	FM MULTIPATH "V"	0.1 Vp-p

3. Horizontal deflection sensitivity check

- 1) Set the operating controls on the front panel in the same manner as in the vertical deflection sensitivity check given in item **IV 2** above, excepting those controls which should be set as follows:

SELECTOR: STEREO DISPLAY

HORIZONTAL GAIN: Extreme clockwise

VERTICAL GAIN: Extreme counterclockwise

- 2) Apply the 0.1 Vp-p output from the square wave voltage calibrator to the RIGHT input terminal on the front panel and check to see that the input signal is horizontally deflected more than 40 mm, as measured on the cathode-ray tube scope.
- 3) With the operating controls set as follows, check to see that the terminals on the rear panel provide a horizontal deflection sensitivity of more than 40 mm respectively against their inputs.

AUDIO INPUT: REAR

SELECTOR's position: Input terminal
Calibrator's output

STEREO DISPLAY: AUDIO INPUT "R" 1Vp-p

FM MULTIPATH: FM MULTIPATH "H"
0.1Vp-p

V. Frequency Response Check

1. Purpose

The purpose of this frequency response check is to check the audio lab-scope for proper vertical and horizontal frequency responses.

2. Set the operating controls on the front panel as follows:

SELECTOR: STEREO DISPLAY

AUDIO INPUT: FRONT

HORIZONTAL GAIN: Center

VERTICAL GAIN: Center

INTENSITY: 3 o'clock position

FOCUS: Any position for which bright spot is focussed properly

3. Vertical frequency response

- 1) With the 1 kHz sine wave output from the sine wave oscillator applied to the LEFT terminal on the front panel adjust the output of the oscillator until the input signal to the audio-lab scope is vertically deflected 40 mm, as measured on the scope.

Monitor the output level of the oscillator using an AC voltmeter or an oscilloscope under the above condition.

- 2) Set the oscillator frequency at 150 kHz and make sure that the output level of the oscillator remains as monitored in item 1) above. If not, adjust the output level to the same level as monitored in item 1).

Check to see under the above condition that the input signal to the audio-lab scope is deflected vertically more than 28 mm.

4. Horizontal frequency response check

Proceed just in the same manner as described in item 3 above with the output signal from the sine wave oscillator applied to the RIGHT input terminal on the front panel.

5. Check of SAG

Set the operating controls on the front panel as follows:

SELECTOR: WAVE FORM RIGHT

SWEEP RANGE: 10K – 100K

SWEEP VARIABLE: Center

Apply the 50 Hz square wave output from the square wave oscillator to the RIGHT input terminal on the front panel.

Adjust the output of the oscillator until the input signal is deflected 40 mm as measured on the scope. Check to see under the above condition that the upper and lower horizontal bands offer a vertical width of 2 mm or less.

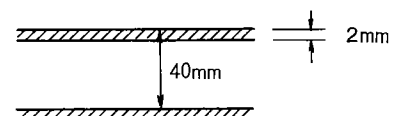

ALIGNMENT PROCEDURE

VI. Sweep Oscillator Frequency Check

1. Purpose
The purpose of this sweep oscillator frequency check is to check the sweep oscillator frequency of the model KC-6060A for proper continuity.
2. Set the operating controls on the front panel as follows:
SELECTOR: WAVE FORM LEFT
SWEEP RANGE: 10 – 100
SWEEP VARIABLE: Extreme counterclockwise
VERTICAL GAIN: Center
HORIZONTAL GAIN: The position for which the input signal is horizontally deflected approx. 40 mm

Apply the 10 Hz sine wave output from the sine wave oscillator to the LEFT input terminal. Then, adjust the output of the oscillator until the waveform on the cathode-ray scope provides an appropriate vertical amplitude.

Check the sweep oscillator frequency for normal continuity by carrying out the following steps:

- 1) While turning the SWEEP VARIABLE control clockwise, check to see that one cycle of the input signal frequency waveform comes to a standstill on the scope to indicate its synchronization to the sweep oscillator frequency.

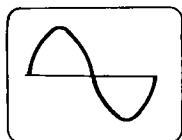

- 2) Set the oscillator frequency at 100 Hz.
While turning the SWEEP VARIABLE control clockwise, check to see that one cycle of the input signal frequency waveform comes to a standstill.
- 3) Set the SWEEP RANGE switch at the 100 – 1K position.
While turning the SWEEP VARIABLE control counterclockwise, check to see that one cycle of the input signal frequency waveform comes to a standstill.

- 4) Set the oscillator frequency at 1 kHz.
While turning the SWEEP VARIABLE control clockwise, check to see that one cycle of the input signal frequency waveform comes to a standstill.
- 5) Set the SWEEP RANGE switch at the 1K – 100K position.
While turning the SWEEP VARIABLE control counterclockwise, check to see that one cycle of the input signal frequency waveform comes to a standstill.
- 6) Set the oscillator frequency at 10 kHz.
While turning the SWEEP VARIABLE control clockwise, check to see that one cycle of the input signal frequency waveform comes to a standstill.
- 7) Set the SWEEP RANGE switch at the 10K – 100K position.
While turning the SWEEP VARIABLE control counterclockwise, check to see that one cycle of the input signal frequency waveform comes to a standstill.
- 8) Set the oscillator frequency at 100 kHz.
While turning the SWEEP VARIABLE control clockwise, check to see that one cycle of the input signal frequency waveform comes to a standstill.

Note: *If the input oscillator frequency fails to synchronize with the sweep oscillator frequency at a frequency range, perform the check with the SWEEP RANGE switch set at the next or preceding frequency range. If the check is performed successfully, then it may be considered that the continuity of the sweep oscillator frequency is normal.*

VII. Sweep Linearity Adjustment

1. Purpose
The purpose of this adjustment is to adjust the sweep oscillator of the model KC-6060A for normal sweep linearity within a sweep range of 10K – 100K.
2. Set the operating controls on the front panel as follows:
SELECTOR: RIGHT
SWEEP RANGE: 10K – 100K

Apply the 100kHz sine wave output from the sine wave oscillator to the RIGHT input terminal, adjust the SWEEP VARIABLE control until 7 cycles of the input signal waveform appear on the cathode-ray tube scope.

Adjust the HORIZONTAL GAIN control until the above-mentioned 7 cycles of waveform start and

ALIGNMENT PROCEDURE

terminate respectively at the points 20 mm away from the center line of the CRT scope as shown in the figure below.

Adjust trimmer capacitor TC1 on printed circuit board UM1302J until the center bottom peak of the waveform coincide with the center of the horizontal line of CRT scale.

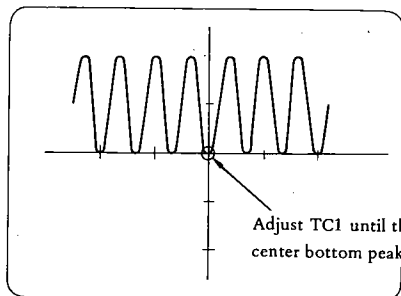

VIII. Check of Input Signal Synchronization

1. Purpose

The purpose of this check is to make sure that the input signal frequency is synchronized normally with the sweep oscillator frequency of model KC-6060A.

2. Set the operating controls on the front panel as follows:

SELECTOR: RIGHT
SWEEP RANGE: 10K – 100K

With the 200 kHz sine wave applied to the RIGHT input terminal, adjust the VERTICAL GAIN control until the input signal is vertically deflected 10 mm, as measured on the cathode-ray tube scope.

Check under the above condition to see that the waveform on the scope can be brought in a standstill by turning the SWEEP VARIABLE control.

- 1) With the SWEEP RANGE switch set at the 100 – 1K position and the 1 kHz sine wave applied to the RIGHT input terminal, proceed just in the same manner as described in item 2 above to make sure that the waveform on the scope can be brought in a standstill.
- 2) Also, check that the input signal frequency is synchronized with the sweep oscillator frequency with its trailing edge swinging downward as shown below.

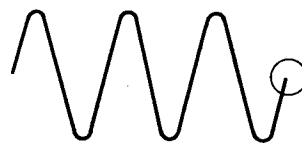

IX. Calibration of Test Signal and Its Check

1. Purpose

The purpose of this calibration is to calibrate the 1 kHz calibrator for its peak-to-peak voltage.

2. Set the operating controls on the front panel as follows:

SELECTOR: LEFT
SWEEP RANGE: 100 – 1K
HORIZONTAL GAIN: Center

1) Apply the 1 kHz, 0.1 Vp-p square wave to the LEFT input terminal.

Turn the VERTICAL GAIN control until the waveform on the cathode-ray tube scope provides an amplitude of 40 mm.

2) With the SELECTOR switch turned to the TEST (0.1 Vp-p) position, adjust variable resistor VR1 on printed circuit board UM1302J until the sine waves provide a peak-to-peak value of 40 mm, as measured on the cathode-ray tube scope.

3) Connect the AC voltmeter to the 1 kHz OSC OUTPUT on the rear panel. While observing the voltmeter, check to see that the meter increases its indication from 0 up to 0.9 V r.m.s. or more as the 1 kHz OSC control on the front panel is turned clockwise from the extreme counterclockwise to the extreme clockwise positions.

4) Then connect the distortion meter to the terminal on the rear panel mentioned above. Check to see that the meter indicates a distortion factor of 2% or less and a frequency reading of 1 kHz \pm 10%.

■ REPLACEMENT OF CATHODE-RAY TUBE

1. Remove the screws, which hold the cathode-ray tube shielding case in position as shown the followings.
2. Turn the cathode-ray tube shielding case clockwise and lift it up out of the cabinet case.

ALIGNMENT PROCEDURE

3. Loosen the clamber screw holding the cathode-ray tube in its shielding case and pull the tube out of the case.
4. Remove the rubber cushion from the neck of the removed cathode-ray tube. Apply the cushion to a new cathode-ray tube. Then, mount the new cathode-ray tube in the cabinet case by carrying out steps 1, 2, and 3 reversely both in sequence and operations.

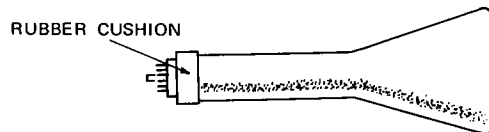
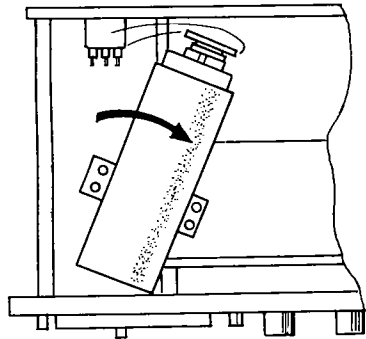
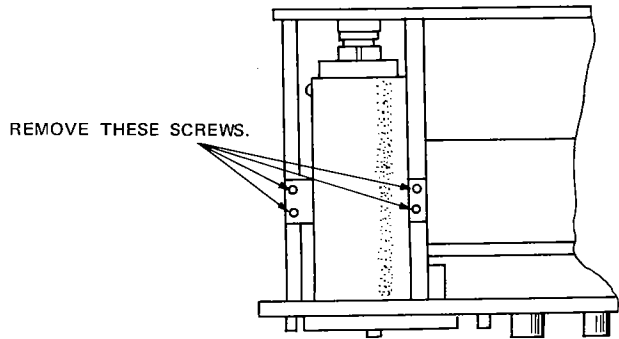

BLOCK DIAGRAM

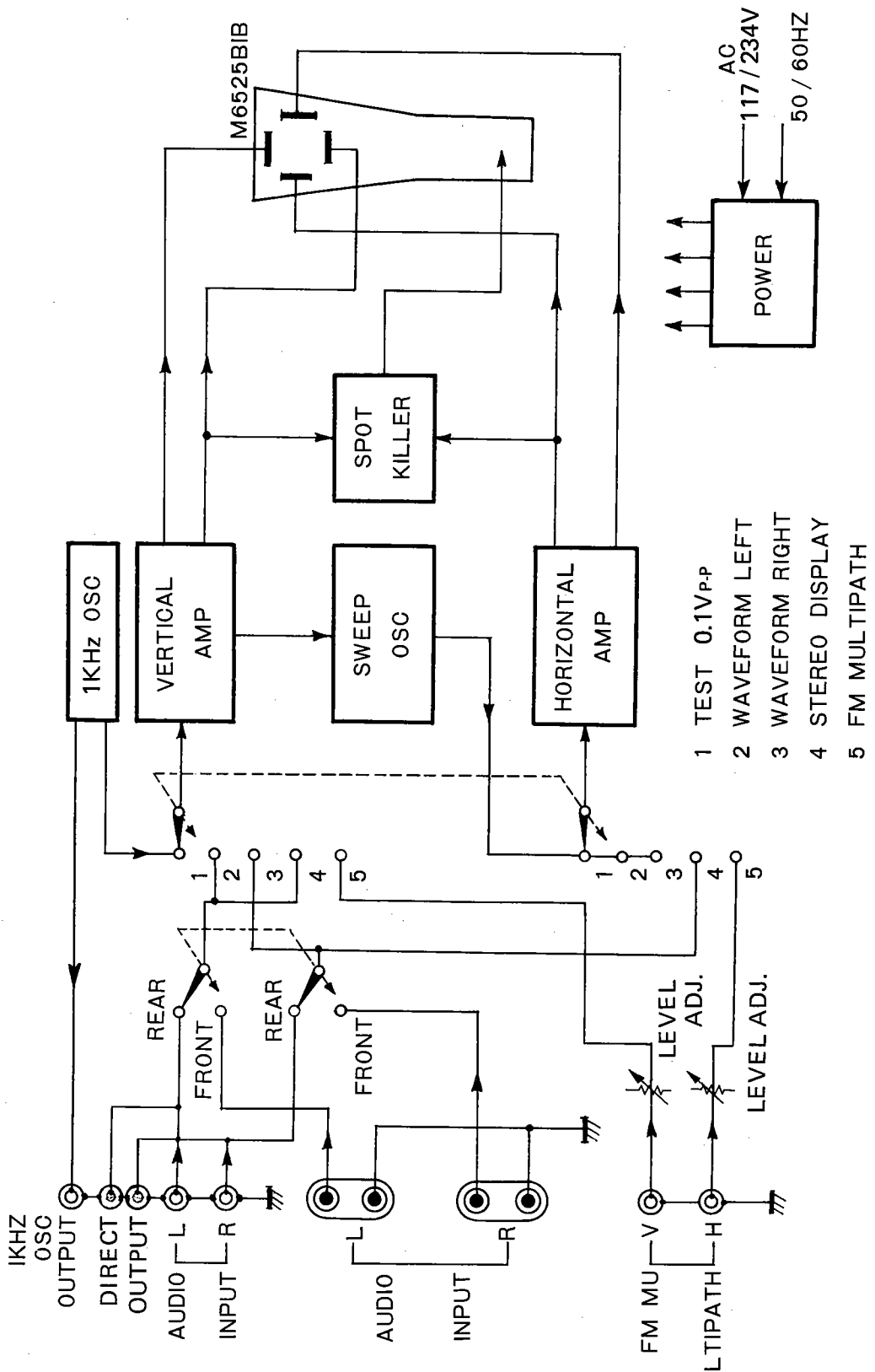

SCHEMATIC DIAGRAM

BOTTOM VIEW OF TRANSISTOR

2SC458C

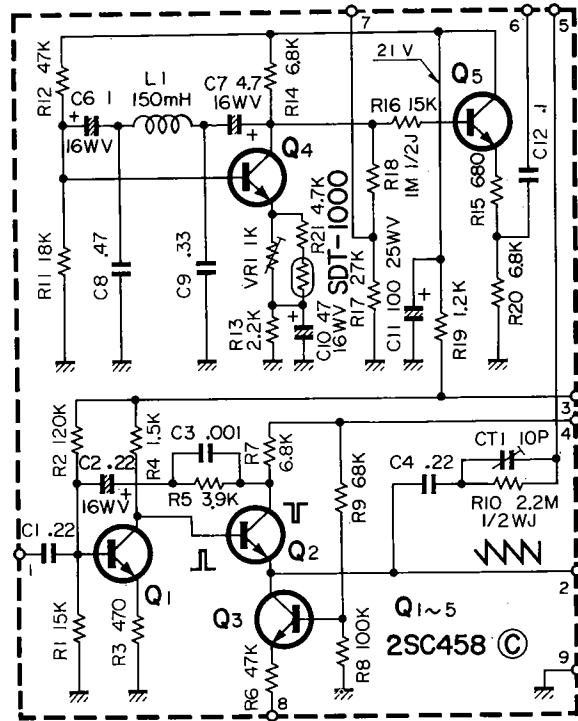

SEALED CIRCUIT ASSEMBLIES-PHANTOM VIEWS

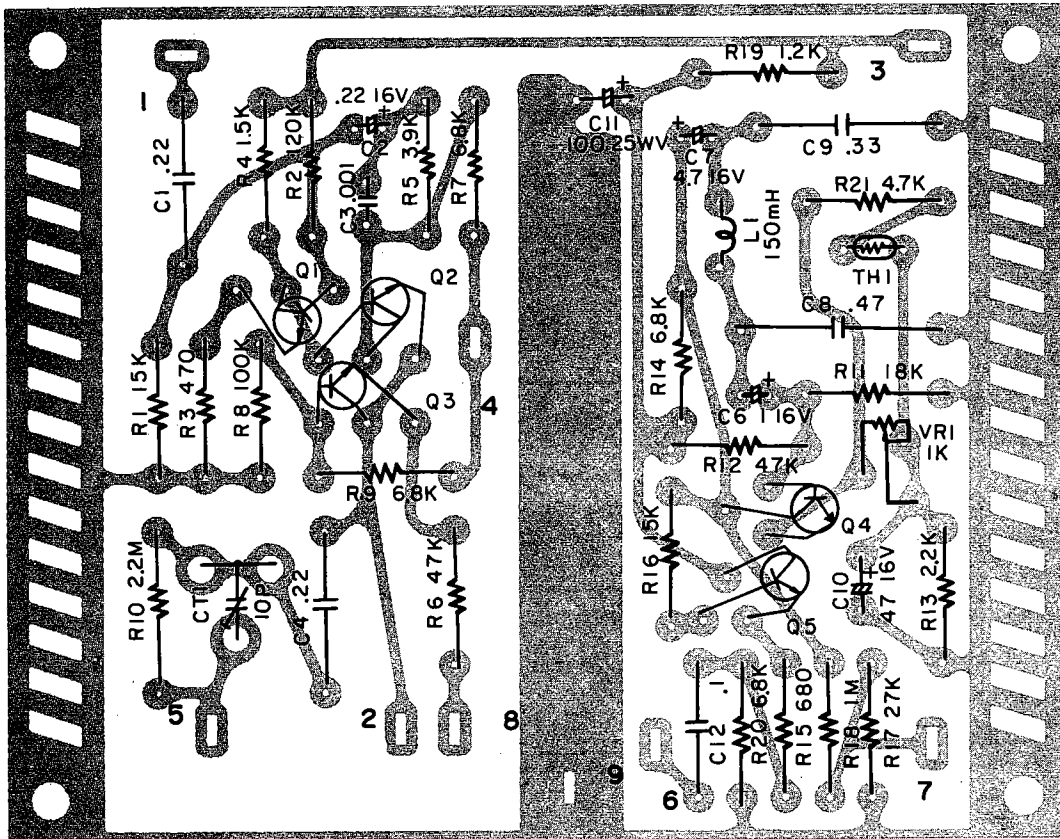

Q1~5 2SC458(C) TH1 SDT-1000

Symbol No.	Description	Part No.	Remarks
CAPACITORS			
C1	Mylar	0.22 μ F \pm 20%	CQ93M1H224M
C2	Solid Aluminum	0.22 μ F 16WV	CA04W1CR22
C3	Ceramic	0.001 μ F \pm 20%	CK94YY1H102M
C4	Mylar	0.22 μ F \pm 20%	CQ93M1H224M
C6	Electrolytic Tubular	1 μ F 16WV	CE04W1C010
C7	Electrolytic Tubular	4.7 μ F 16WV	CE04W1C4R7
C8	Mylar	0.47 μ F \pm 10%	CQ93M1H474K
C9	Mylar	0.33 μ F \pm 10%	CQ93M1H334K
C10	Electrolytic Tubular	47 μ F 16WV	CE04W1C470
C11	Electrolytic Tubular	100 μ F 25WV	CE04W1E101
C12	Mylar	0.1 μ F \pm 20%	CQ93M1H104M
CT1	Ceramic Trimmer	10pF	C05-0010-05
RESISTORS			
R1	Insulated Carbon Film	15k Ω \pm 5% 1/4W	PD14BY2E153J
R2	Insulated Carbon Film	120k Ω \pm 5% 1/4W	PD14BY2E124J
R3	Insulated Carbon Film	470 Ω \pm 5% 1/4W	PD14BY2E471J
R4	Insulated Carbon Film	1.5k Ω \pm 5% 1/4W	PD14BY2E152J
R5	Insulated Carbon Film	3.9k Ω \pm 5% 1/4W	PD14BY2E392J
R6	Insulated Carbon Film	47k Ω \pm 5% 1/4W	PD14BY2E473J
R7	Insulated Carbon Film	6.8k Ω \pm 5% 1/4W	PD14BY2E682J
R8	Insulated Carbon Film	100k Ω \pm 5% 1/4W	PD14BY2E104J
R9	Insulated Carbon Film	68k Ω \pm 5% 1/4W	PD14BY2E683J
R10	Insulated Carbon Film	2.2M Ω \pm 5% 1/2W	PD14BY2H225J
R11	Insulated Carbon Film	18k Ω \pm 5% 1/4W	PD14BY2E183J
R12	Insulated Carbon Film	47k Ω \pm 5% 1/4W	PD14BY2E473J
R13	Insulated Carbon Film	2.2k Ω \pm 5% 1/4W	PD14BY2E222J
R14	Insulated Carbon Film	6.8k Ω \pm 5% 1/4W	PD14BY2E682J
R15	Insulated Carbon Film	680 Ω \pm 5% 1/4W	PD14BY2E681J
R16	Insulated Carbon Film	15k Ω \pm 5% 1/4W	PD14BY2E153J
R17	Insulated Carbon Film	27k Ω \pm 5% 1/4W	PD14BY2E273J
R18	Insulated Carbon Film	1M Ω \pm 5% 1/2W	PD14BY2H105J
R19	Insulated Carbon Film	1.2k Ω \pm 5% 1/4W	PD14BY2E122J
R20	Insulated Carbon Film	6.8k Ω \pm 5% 1/4W	PD14BY2E682J
R21	Insulated Carbon Film	4.7k Ω \pm 5% 1/4W	PD14BY2E472J
TRANSISTOR/THERMISTOR			
Q1~5	2SC458 (C)		
TH1	SDT-1000		
POTENTIOMETER			
VR1	1k Ω (B)		
etc.			
-	Printed Circuit Board	J25-0013-04	
L1	Ferri-Inductor (FL11H-154J)	L33-0127-05	

SCHEMATIC DIAGRAM

BOTTOM VIEW OF TRANSISTOR

2SC627



2SC458(C)

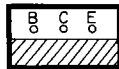

2SK30

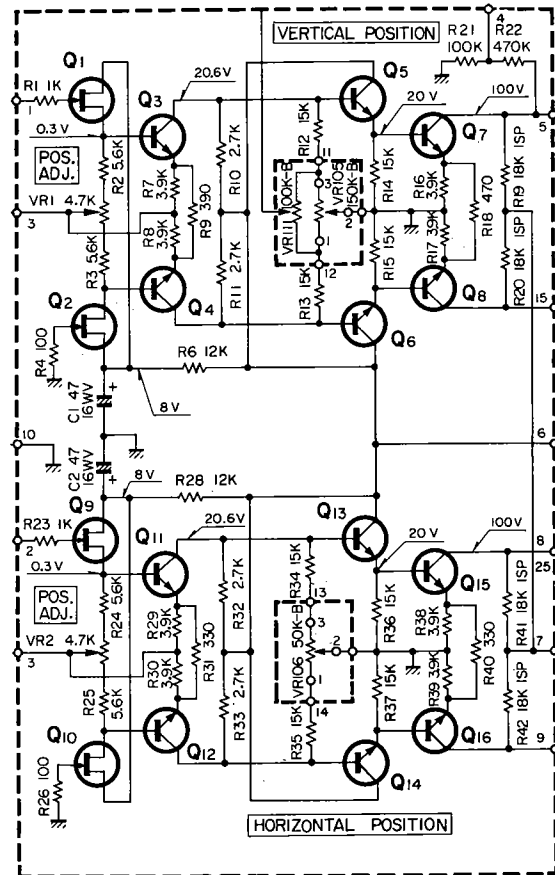

SEALED CIRCUIT ASSEMBLIES-PHANTOM VIEWS

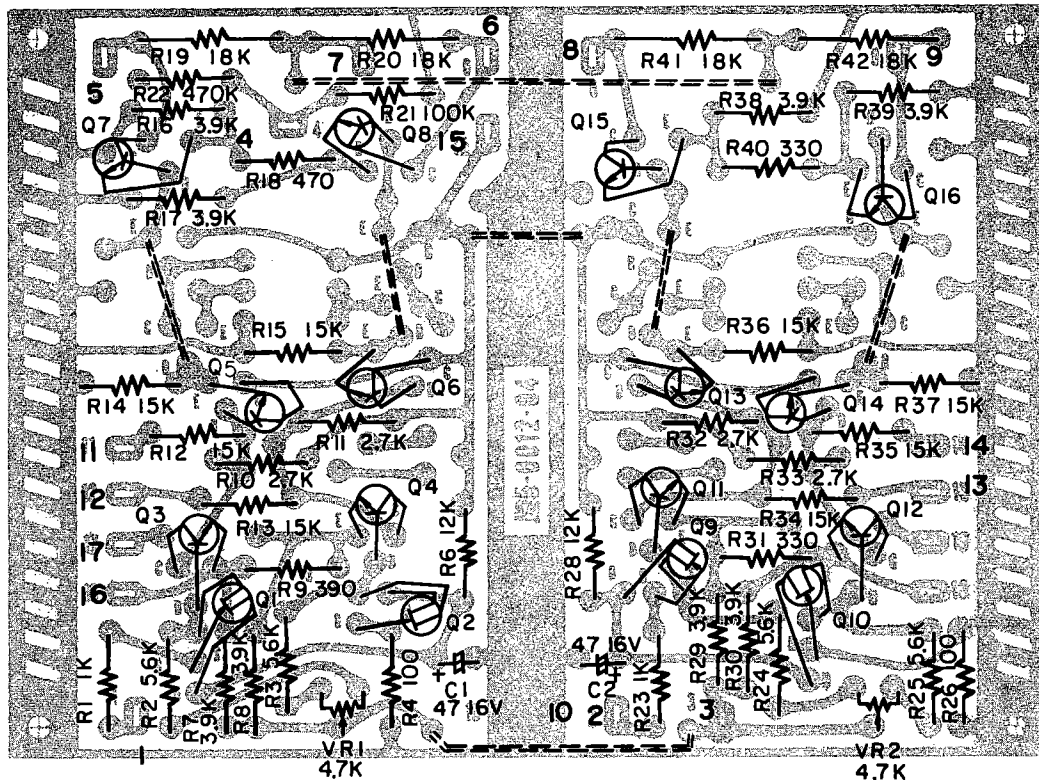

Q1,2,9,10 2SK30(O), Q3~6,11~14 2SC458(C), Q7,8,15,16 2SC627(2)

Symbol No.	Description	Part No.	Remarks
CAPACITORS			
C1, 2	Electrolytic Tubular 47 μ F 16WV	CE04W1C470	
RESISTORS			
R1	Insulated Carbon Film 1k Ω \pm 5% 1/4W	PD14BY2E102J	
R2, 3	Insulated Carbon Film 5.6k Ω \pm 5% 1/4W	PD14BY2E562J	
R4	Insulated Carbon Film 100 Ω \pm 5% 1/4W	PD14BY2E101J	
R6	Insulated Carbon Film 12k Ω \pm 5% 1/4W	PD14BY2E123J	
R7, 8	Insulated Carbon Film 3.9k Ω \pm 5% 1/4W	PD14BY2E392J	
R9	Insulated Carbon Film 390 Ω \pm 5% 1/4W	PD14BY2E391J	
R10, 11	Insulated Carbon Film 2.7k Ω \pm 5% 1/4W	PD14BY2E272J	
R12~15	Insulated Carbon Film 15k Ω \pm 5% 1/4W	PD14BY2E153J	
R16, 17	Insulated Carbon Film 3.9k Ω \pm 5% 1/4W	PD14BY2E392J	
R18	Insulated Carbon Film 470 Ω \pm 5% 1/4W	PD14BY2E471J	
R19, 20	Metal Film 18k Ω \pm 5% 1W	RN14AB3A183J	
R21	Insulated Carbon Film 100k Ω \pm 5% 1/4W	PD14BY2E104J	
R22	Insulated Carbon Film 470k Ω \pm 5% 1/4W	PD14BY2E474J	
R23	Insulated Carbon Film 1k Ω \pm 5% 1/4W	PD14BY2E102J	
R24, 25	Insulated Carbon Film 5.6k Ω \pm 5% 1/4W	PD14BY2E562J	
R26	Insulated Carbon Film 100 Ω \pm 5% 1/4W	PD14BY2E101J	
R28	Insulated Carbon Film 12k Ω \pm 5% 1/4W	PD14BY2E123J	
R29, 30	Insulated Carbon Film 3.9k Ω \pm 5% 1/4W	PD14BY2E392J	
R31	Insulated Carbon Film 330 Ω \pm 5% 1/4W	PD14BY2E331J	
R32, 33	Insulated Carbon Film 2.7k Ω \pm 5% 1/4W	PD14BY2E272J	
R34~37	Insulated Carbon Film 15k Ω \pm 5% 1/4W	PD14BY2E153J	
R38, 39	Insulated Carbon Film 3.9k Ω \pm 5% 1/4W	PD14BY2E392J	
R40	Insulated Carbon Film 330 Ω \pm 5% 1/4W	PD14BY2E331J	
R41, 42	Metal Film 18k Ω \pm 5% 1W	RN14AB3A183J	
TRANSISTORS/FET			
Q1, 2	2SK30 (0)		
Q3~6	2SC458(C)		
Q7, 8	2SC627(2)		
Q9, 10	2SK30(0)		
Q11~14	2SC458(C)		
Q15, 16	2SC627(2)		
POTENTIOMETER			
VR1	"V" POSITION ADJ. 4.7k Ω (B)	R12-1004-05	
VR2	"H" POSITION ADJ. 4.7k Ω (B)	R12-1004-05	
PC BOARD			
—	PC Board	J25-0012-14	

SCHEMATIC DIAGRAM

BOTTOM VIEW OF TRANSISTOR

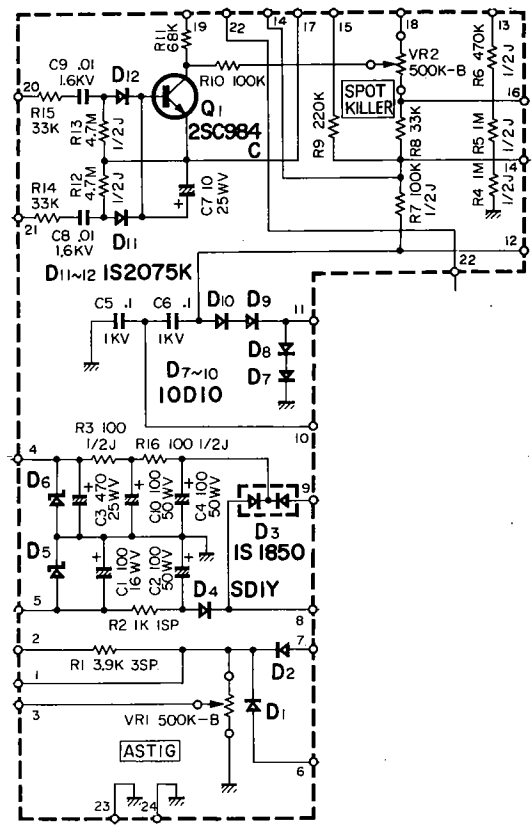
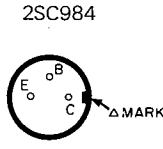

SEALED CIRCUIT ASSEMBLIES-PHANTOM VIEWS

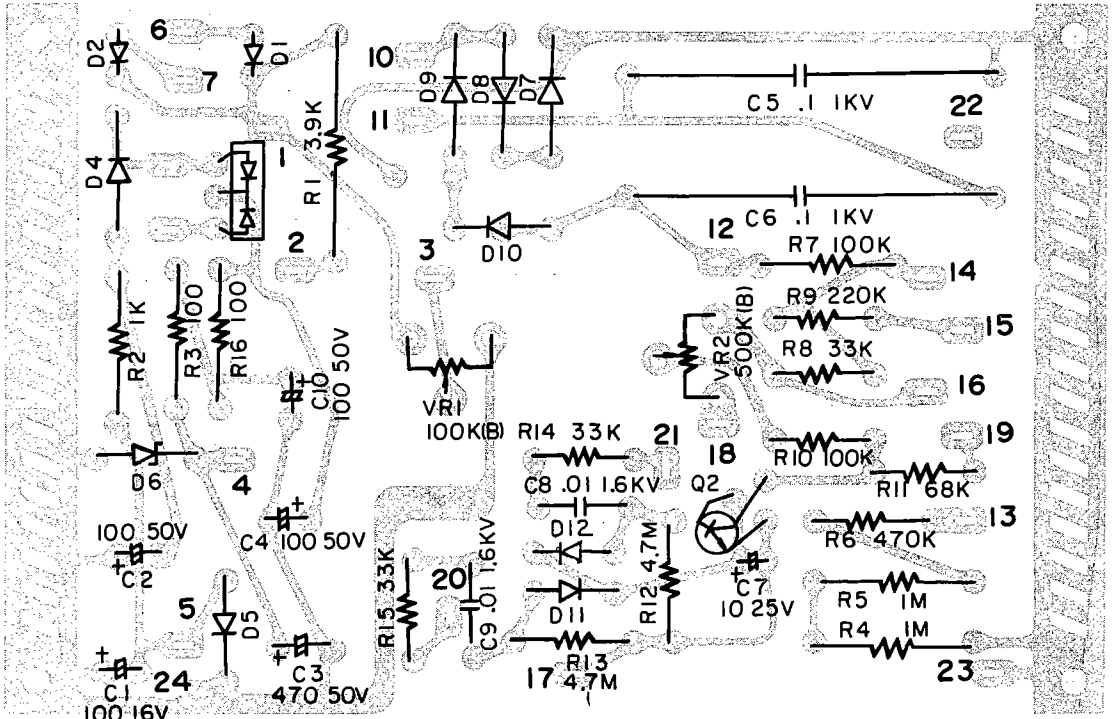

- Q2 2SC984(C) D1,2 SW-05(G) D3 IS1850 D4 SD-1Y, D5 2B1-6
 D6 SZ-200-25, D7~10 10D10 D11,12 IS1473K

Symbol No.	Description			Part No.	Remarks
CAPACITORS					
C1	Electrolytic Tubular	100 μ F	16WV	CE04W1C101	
C2	Electrolytic Tubular	100 μ F	50WV	CE04W1H101	
C3	Electrolytic Tubular	470 μ F	25WV	CE04W1E471	
C4	Electrolytic Tubular	100 μ F	50WV	CE04W1H101	
C5, 6	Oil Impregnated Paper	0.1 μ F	\pm 20%	CP02B3A104M	
C7	Electrolytic Tubular	10 μ F	25WV	CE04W1E100	
C8, 9	Ceramic	0.01 μ F	\pm 20%	CK94YY3C103M	
C10	Electrolytic Tubular	100 μ F	50WV	CE04W1H101	
RESISTORS					
R1	Metal Film	3.9k Ω	\pm 5%	3W	RN14AB3F392J
R2	Metal Film	1k Ω	\pm 5%	1W	RN14AB3A102J
R3	Insulated Carbon Film	100 Ω	\pm 5%	1/2W	PD14BY2H101J
R4, 5	Insulated Carbon Film	1M Ω	\pm 5%	1/2W	PD14BY2H105J
R6	Insulated Carbon Film	470k Ω	\pm 5%	1/2W	PD14BY2H474J
R7	Insulated Carbon Film	100k Ω	\pm 5%	1/2W	PD14BY2H104J
R8	Insulated Carbon Film	33k Ω	\pm 5%	1/4W	PD14BY2E333J
R9	Insulated Carbon Film	220k Ω	\pm 5%	1/4W	PD14BY2E224J
R10	Insulated Carbon Film	100k Ω	\pm 5%	1/4W	PD14BY2E104J
R11	Insulated Carbon Film	68k Ω	\pm 5%	1/4W	PD14BY2E683J
R12, 13	Insulated Carbon Film	4.7M Ω	\pm 5%	1/2W	PD14BY2H475J
R14, 15	Insulated Carbon Film	33k Ω	\pm 5%	1/4W	PD14BY2E333J
R16	Insulated Carbon Film	100 Ω	\pm 5%	1/2W	PD14BY2H101J
POTENTIOMETER					
VR1	ASTIGMATISM ADJ.	500k Ω (B)			R12-7001-05
VR2	SPOT KILLER ADJ.	500k Ω (B)			R12-7001-05
TRANSISTOR/DIODES					
Q1	2SC984(C)				
D1, 2	SW-05 (Gray)				
D3	1S1850				
D4	SD-1Y				
D5	ZB1-6				
D6	SZ-200-25				
D7~10	10D10				
D11, 12	1S1473(K)				
PC BOARD					
—	PC Board				J25-0014-14

KENWOOD ELECTRONICS, INC.

- 15777 SOUTH BROADWAY, GARDENA, CALIFORNIA 90247
- 72-02 51ST AVENUE, WOODSIDE, N.Y. 11377

CANADIAN EXCLUSIVE DISTRIBUTOR

MAGNASONIC CANADA LTD.

- 4980 BUCHAN ST. MONTREAL P.Q, CANADA
- 14 BANIGAN DRIVE THORNCLIFFE PARK TORONTO CANADA